

未注公差/General tolerances(mm)											0.1/10 ±2'		
0	>3	>6	>10	>18	>30	>50	>80	>120	>180	>250			
~3	~6	~10	~18	~30	~50	~80	~120	~180	~250	~315	~400	~500	>500
±0.12	±0.18	±0.22	±0.26	±0.31	±0.37	±0.57	±0.80	±0.93	±1.05	±1.15	±1.60	±2.20	±2.50

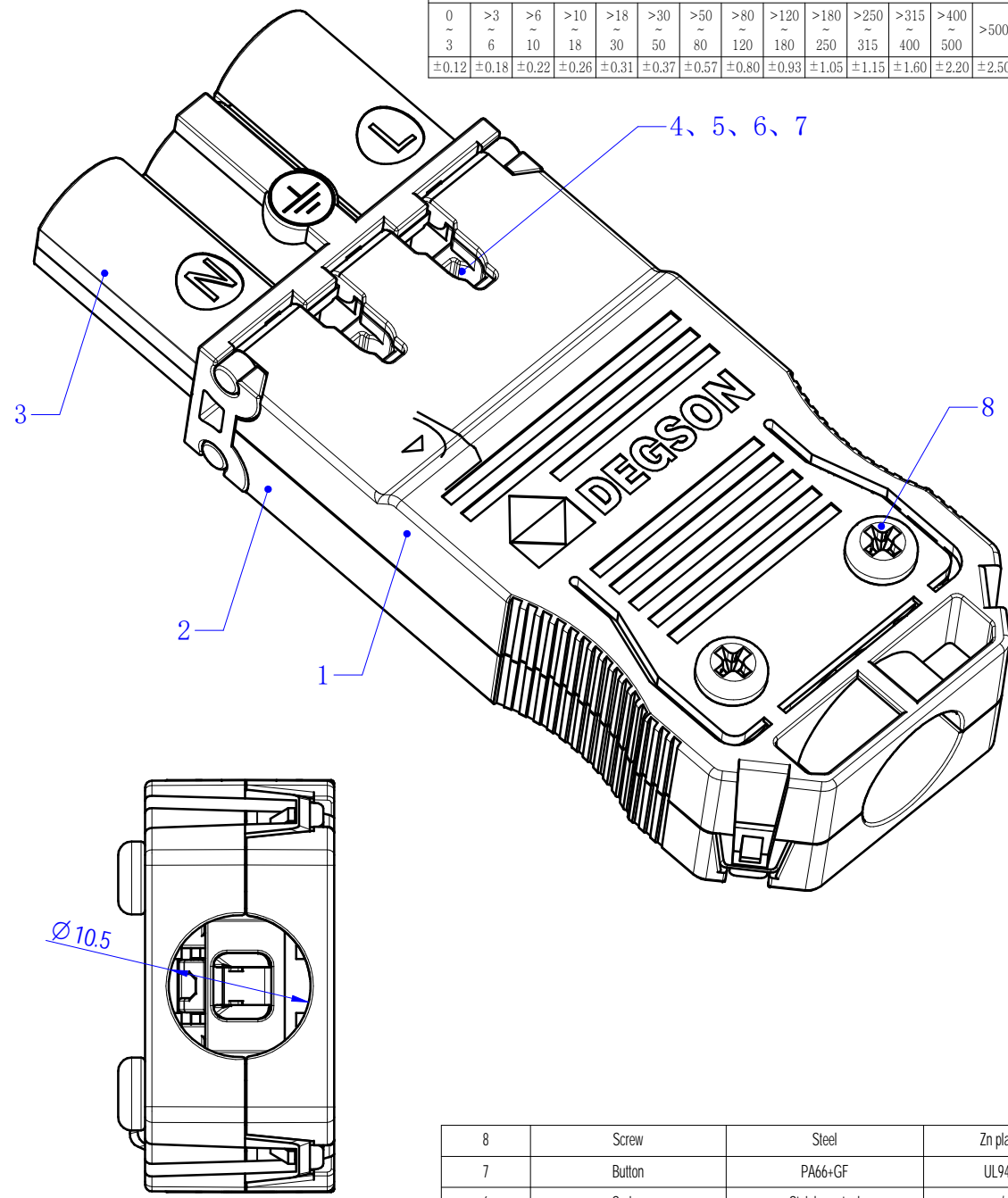
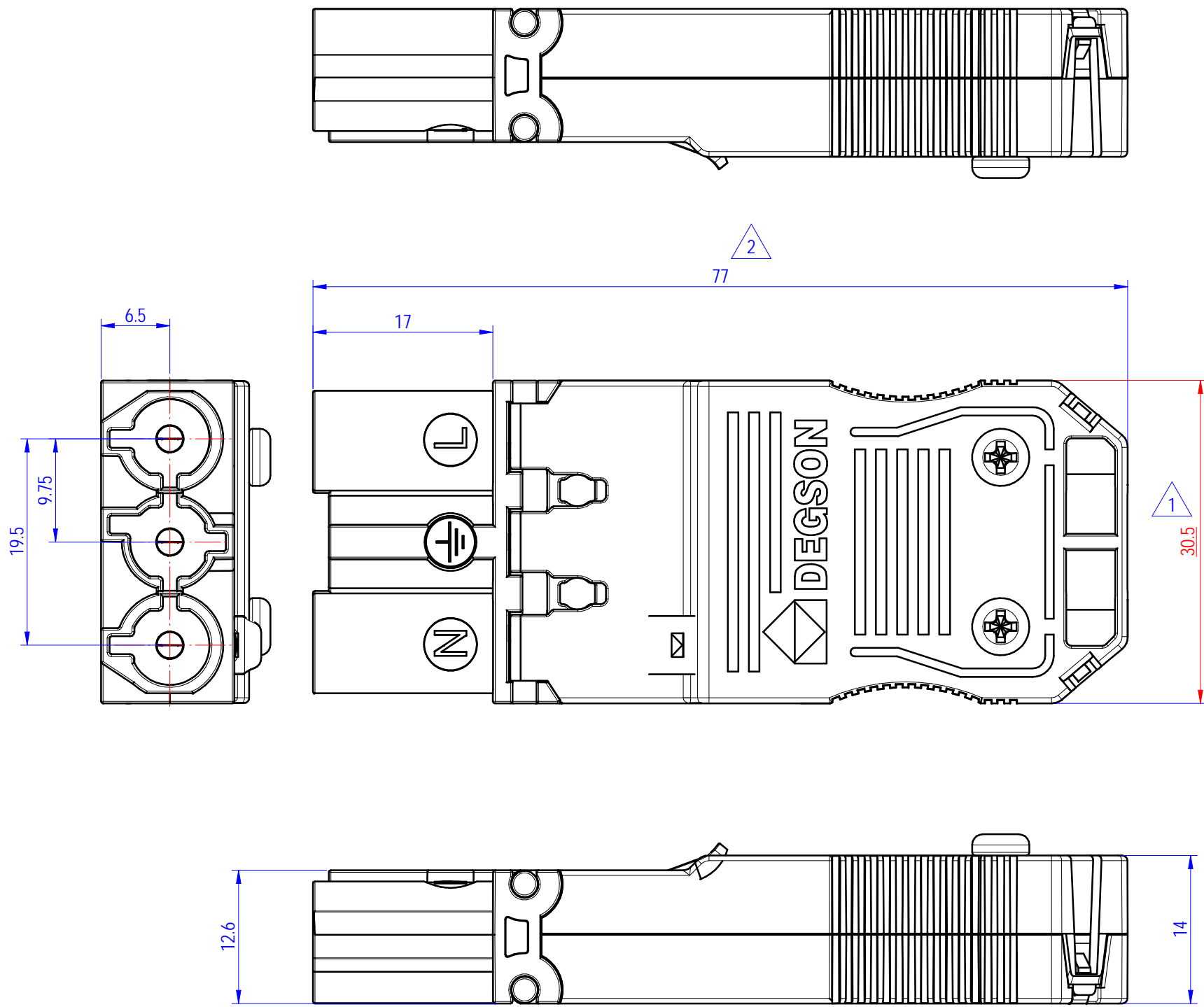

ITEM	NAME OF PART	MATERIAL	NOTES
8	Screw	Steel	Zn plated
7	Button	PA66+GF	UL94V-0
6	Spring	Stainless steel	/
5	Male pin	Copper alloy	Sn Plated
4	Cover	PA66+GF	UL94V-0
3	Housing	PA66+GF	UL94V-0
2	Bottom cover	PA66	UL94V-0
1	Top cover	PA66	UL94V-0

UL 标准/UL Standard: (UL1977)		600V/20A
额定电压/电流/Rated Voltage(V)/Current(A)		
IEC 标准/IEC Standard:(IEC61535)		
额定电压/电流/Rated Voltage(V)/Current(A)		250/400V,32A
额定脉冲电压(KV)/Rate Impulse Voltage(KV)		4
螺丝扭矩/Torque Tightening(N·m/Lb.in)		ST2.9, 1.0/8.8
线径范围(硬线和软线)/Wire Range(rigid and flexible)(AWG/mm²)		20~12 / 0.5~4
间距/Pitch(mm)/线数范围/Poles		9.75/N=03P
剥线长度/Stripping length(mm)		10~11
使用温度范围/Operating temperature(°C)		-40~+105

DEGSON MATERIAL: / SURFACE/COLOR: /
 MAT NO./REV: / /00 MAT STATUS: /
 APPD: 蓝贵凡 2025.05.12 NAME
 CHKD: 朱伟明 2025.05.12 DGBSC-PG01M/4-03P-1Y-00Z (H)
 DRFT: 汪德荣 2025.05.12 DRAWING NO. 200344567 TYPE CUSTOMER DRAWING DRAWING STATUS / SCALE 2:1 SHEET 1/1

REV	ECN	DESCRIPTION	DRFT	DATE
00	/		汪德荣	2025.05.12

Transfer or duplication of this document as well as the utilization or communication of its contents are prohibited unless explicit authorization is granted. Violations will be liable for compensation. All rights reserved for patent. 复制或再行传播此文件以及其内容之利用或沟通均须经明确授权，否则侵权必究。本公司保留所有权利。未经许可，不得复制或再行传播。 汪德荣 2025.05.12